

## RACOON 2-AXIS SCAN HEAD

# HIGH PERFORMING 2-AXIS SCAN HEAD FOR UNIVERSAL USE

Novanta develops photonics solutions through our globally recognized brands— ARGES, Cambridge Technology, Laser Quantum and Synrad— specializing in cutting-edge components and sub-systems for laser-based diagnostic, analytical, micromachining and fine material processing applications. Powerful lasers, coupled with advanced beam steering and intelligent sub-systems incorporating software and controls, deliver extreme precision and performance, tailored to our customers' demanding applications.



## MULTI-USE SCANNER

Engineered by ARGES, the RACOON is a 2-axis scan head designed for a variety of applications. Ranging from precision cutting, trepanning, structuring, marking and “on-the-fly” machining. Featuring leading performance and functionality into a ultra compact housing to deliver mechanical stability and reliability.

The RACOON is available in apertures up to 16 mm and 21 mm with a variety of options on mirror coatings and f-theta lenses as complete scan solution for industrial system manufacturers and integrators.

The electronic design in state of the art surface mount technology maximizes thermal stability, static and dynamic optical performance in robust housings.

The compact scan head series can be purchased with various interfaces: standard analog inputs, standard XY2-100 protocol or our proprietary interface implementing new features and Plug & Play operation.

## TAILORED ENGINEERING CAPABILITIES

Through our highly specialized expertise and resources we can provide tailored solutions for your application needs. With a large selection of different laser sources, scan heads and handling systems to choose from, we can develop laser processes that are perfectly tailored to a wide variety of customer-specific products, components and materials.

- Laser-specific customization
- Sub-systems that include laser and beam path
- Customer-specific software extensions
- Laser process development
- Sample production

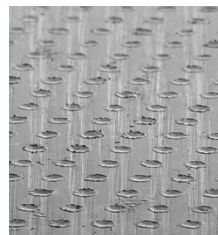

*Laser Structuring*



*Surface Treatment*

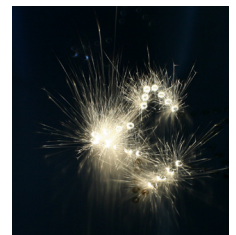

*Laser Cutting*

## RACoon 2-AXIS SCAN HEAD

Specifications	16 mm	21 mm
Aperture	16 mm	21 mm
Beam Displacement	18.4 mm	24.2 mm
Step Response 1%	0.42 ms	0.65 ms
Step Response 10%	0.80 ms	1.05 ms
Step Response 100%	9.00 ms	12.0 ms
Typical Tracking Error	0.30 ms	0.50 ms
Repeatability	< 1.5 $\mu$ rad	
Longterm Offset Drift <sup>1</sup>	< 0.3 mrad	
Scan Angle	0.785 rad	
Skew	< 1.2 mrad	
Linearity	> 99.9%	
Supply Voltage, DC	+/- 24 V	
Supply Voltage, Tolerance	+/- (13.5 ... 28)	
Max Standby Power Consumption	15 W	
Max Current <sup>2</sup>	4 - 6 A	
Ambient Operating Temperature	10°C - 40°C	
Ambient Storage Temperature	0°C - 50°C	
Non-condensing Humidity	10% - 80%	
Cooling Water	DI-water-proof cooling unit with corrosion resistant types of steel	
Pressure	3 - 5 bar	
Max Inlet Temperature	3 bar ~ 5 bar	
Recommended Tubing Material	30°C	
Tube Diameter and Wall Thickness	Polyether Polyurethane	
Weight (excluding lens)	3.1 kg	
Dimensions ( L x W x H)	190 mm x 130 mm x 147.5 mm	

### References:

1. Under constant load and environment over 8 hours. 2. Depending on model

# RACOON 2-AXIS SCAN HEAD

## DIMENSIONS (MM)

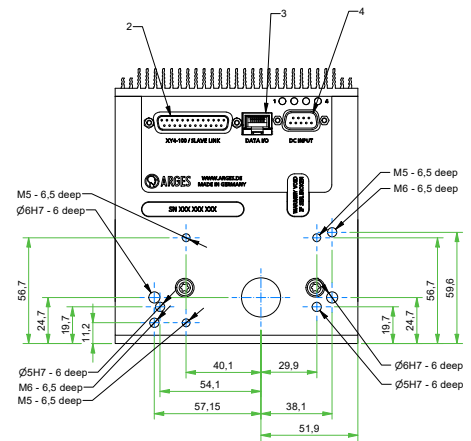
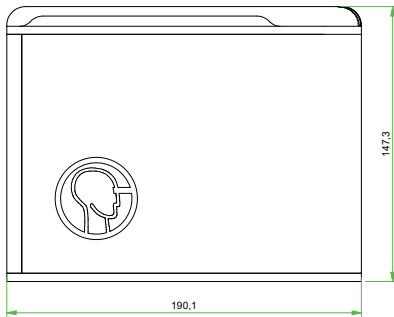
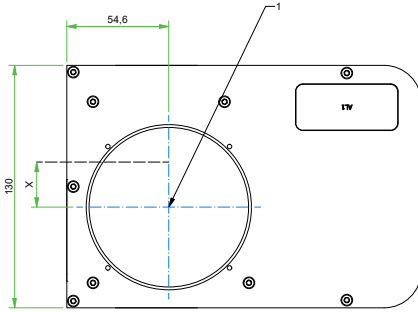

### Notes:

All angles are in optical degrees, unless otherwise noted. Dimensions are in millimeters. All specifications are subject to change without notice.

## CONTACT US

### Americas, Asia Pacific

Novanta Headquarters  
Bedford, USA  
P +1-781-266-5700

Photonics@Novanta.com

### Europe, Middle East, Africa

Novanta Europe GmbH  
Wackersdorf, Germany  
P +49 9431 7984-0

Milan, Italy  
P +39-039-793-710

Photonics@Novanta.com

### China

Novanta Sales & Service Office  
Shenzhen, China  
P +86-755-8280-5395

Suzhou, China  
P +86-512-6283-7080

Photonics.China@Novanta.com

### Japan

Novanta Service & Sales Office  
Tokyo, Japan  
P +81-3-5753-2460

Photonics.Japan@Novanta.com



[www.NovantaPhotonics.com](http://www.NovantaPhotonics.com)