

ELEPHANT, 3-AXIS SCAN HEAD

SCAN HEAD WELDING, CUTTING AND RAPID PROTOTYPING WITH MAXIMUM FLEXIBILITY

Novanta develops photonics solutions through our globally recognized brands— ARGES, Cambridge Technology, Laser Quantum and Synrad— specializing in cutting-edge components and sub-systems for laser-based diagnostic, analytical, micromachining and fine material processing applications. Powerful lasers, coupled with advanced beam steering and intelligent sub-systems incorporating software and controls, deliver extreme precision and performance, tailored to our customers' demanding applications.

VERSATILE SCANNING SOLUTION

The optical design of the ELEPHANT scan head offers a wide range of working field sizes and processing distances and makes it possible to customize the scan head precisely to meet the customer's requirements without altering the overall size of the scan head. The fast Z-axis enables a high-dynamic focus shifting. This allows economical and precise processing of 3-dimensional parts, without changing the position of the part or the scan head. Our solution features an option with and without fiber coupling, the FIBER ELEPHANT, or the ELEPHANT scan head, respectively. Additionally, different wavelength and aperture selections are available to enable the perfect fit for your application. Efficient processes and high flexibility in terms of working volume sizes make the ELEPHANT a future-oriented and versatile solution for welding, cutting, engraving, and perforating.

The FIBER ELEPHANT is the ideal scan head for all robot-assisted applications involving welding and rapid

prototyping with multi-mode fiber lasers, as well as cutting, fine welding, and rapid prototyping with single-mode fiber lasers.

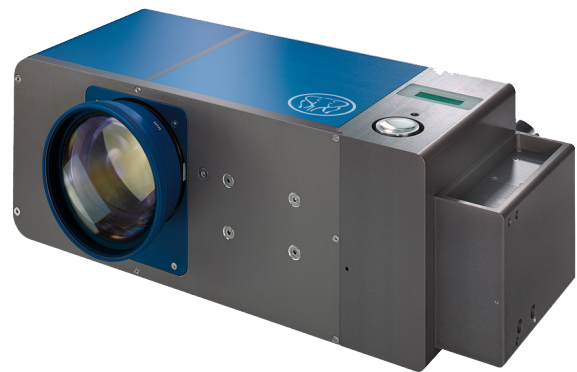
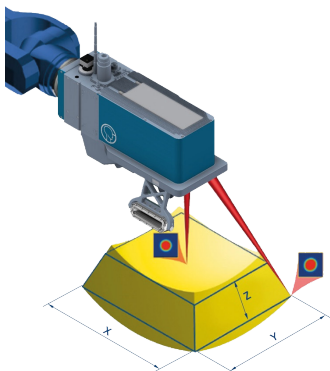

FLEXIBLE SCANNING OPTIONS

Teach-In Option

A teach-in function is available for rapid and convenient positioning of the laser beam on 3D shapes.

The position of the working beam becomes visible via three laser diodes. The point of intersection of all three diodes marks the precise focal point. If there is a change of workpiece, new positioning or repositioning can be carried out efficiently at any time.

SafeScan

The FIBER ELEPHANT is equipped with the ARGES SafeScan safety concept. SafeScan can be configured via the InScript® software and manages and guarantees the high level of safety and availability of the FIBER ELEPHANT

Main features of SafeScan are continuous checking of the laser beam position and monitoring scanner-internal and external system parameters such as temperatures or reference voltages. Various status messages inform the user about any deviations from the target state and facilitate the early planning of preventive maintenance work. If several key variables exceed the safety critical range, the emergency stop interface of the laser is activated via the InScript® software.

ELEPHANT, 3-AXIS SCAN HEAD

Specifications	16 mm	21 mm	36 mm	50 mm
Aperture	16 mm	21 mm	36 mm	50 mm
Fiber Box Option	No	Yes	Yes	Yes
Step Response 1%	0.42 ms	0.65 ms	1.2 ms	2.5 ms
Step Response 10%	0.8 ms	1.05 ms	2.5 ms	4.0 ms
Step Response 100%	9 ms	12 ms	18 ms	30 ms
Tracking Delay	0.3 ms	0.5 ms	0.91 ms	1.5 ms
Step Response Z-axis 1%	2 ms	2 ms	4.5 ms	7.0 ms
Step Response Z-axis 100%	18 ms	18 ms	12 ms	60 ms
Wavelength	1064 nm	355, 532, 1064 nm	1064 nm, 9.3 μm, 10.2 μm, 10.6 μm	
Repeatability	1.5 μrad			
Long Term Offset Drift ¹	< 300 μrad			
Max. Scan Angle per Axis	0.78 rad			
Skew	< 1.2 mrad			
Linearity	> 99.9%			
Supply Voltage, DC	±24 V			
Max. Standby Power Consumption	15 W			
Max. Current	4A - 6A			
Ambient Operating Temperature	10°C - 40°C			
Ambient Storage Temperature	0°C - 50°C			
Non-condensing Humidity	10% - 80%			
Cooling Water	DI-water-proof cooling unit with corrosion resistant types of steel			
Water Pressure	3 bar - 5 bar			
Max. Inlet Temperature	30°C			
Beam Exit Position X	18.4 mm	24.2 mm	35.7 mm	55 mm
Weight (with fiber box)	12.5 kg (18.5 kg)			
Dimensions L x W x H (with fiber box)	350 x 165 x 188.3 mm (425 x 165 x 189.9 mm)			

ADDITIONAL FEATURES

- Option with fiber coupling for 21mm, 36mm and 50mm aperture
- Focus translator as a cost-saving alternative to flat field lens allows a higher flexibility for various applications
- Fiber coupling: Optoskand QBH, Type D, clamp for collimated fibre output Ø 30 or 35 mm; others on request
- Fiber collimator with 80, 100, 120, 150, 170 or 200 mm focal length – adjusted to application and laser
- Diffraction-limited optical design
- Transmission: > 97 % for high power applications
- Open “optical interface” for process monitoring, e.g. by means of vision module, for connecting a teach-in pilot laser, etc.
- Control via InScript® software and ARGES system controller
- Sealed housing
- Quick-change system for protective glass
- Options: water cooling; thermal stabilisation; vision module with camera; teach-in pilot laser
- Easily removable robot flange – available for robots from all the major manufacturers

References:

1. Under constant load and environment over 8 hours.

ELEPHANT, 3-AXIS SCAN HEAD

ALL APERTURES (ELEPHANT)

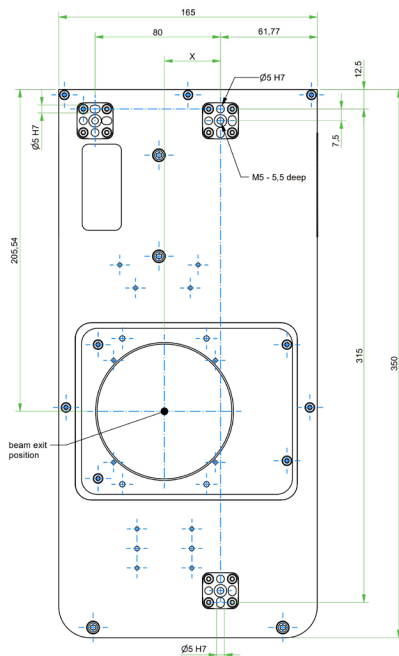
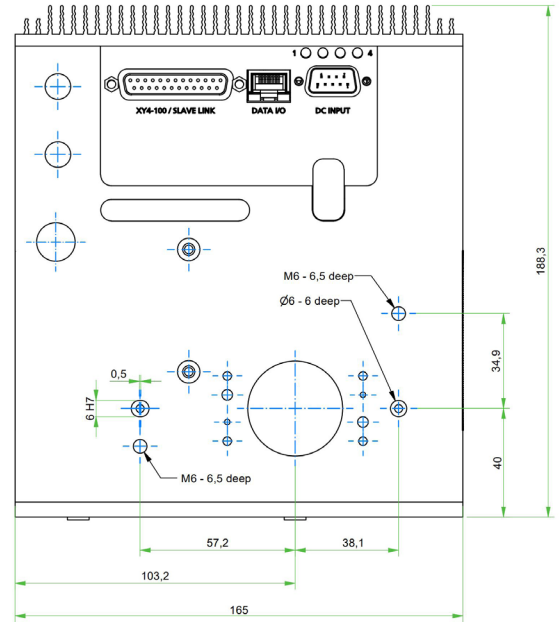
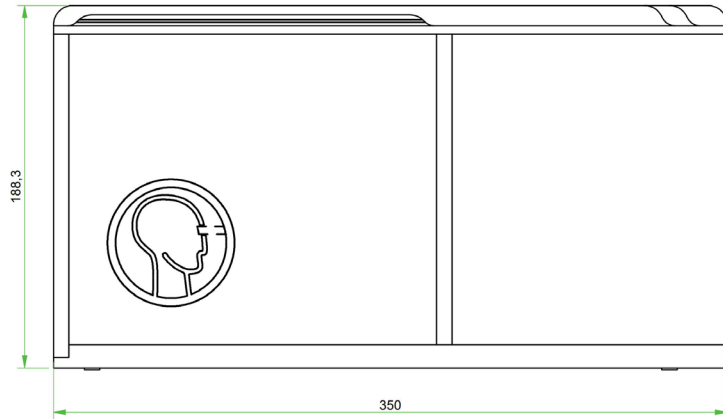

Dimensions for apertures 16, 21 and 36mm

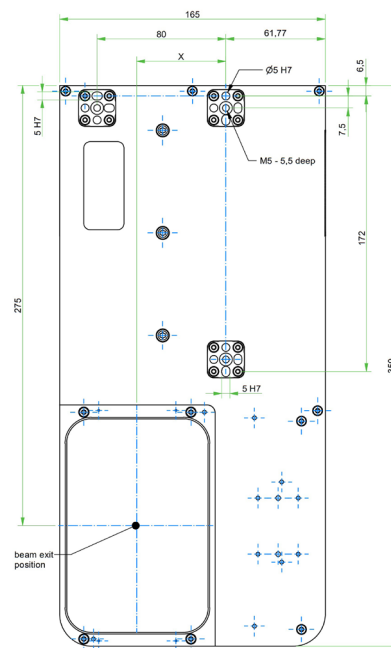

Dimensions for aperture 50 mm

Notes:

All angles are in optical degrees, unless otherwise noted. Dimensions are in millimeters. All specifications are subject to change without notice.

ELEPHANT 3-AXIS SCAN HEAD

FIBER ELEPHANT 36 MM

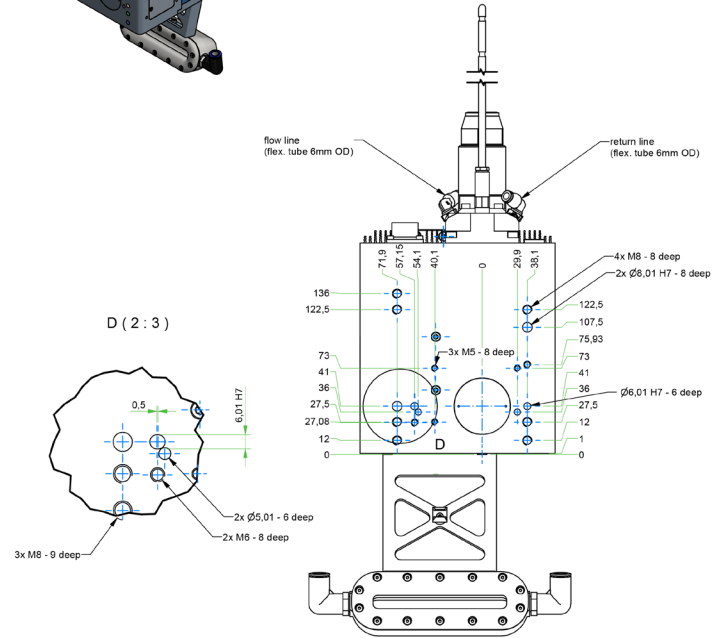
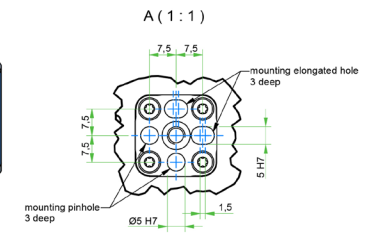
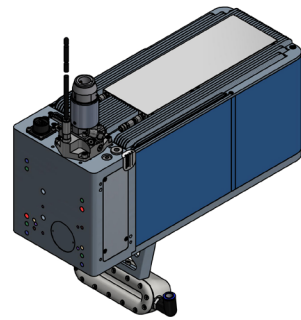
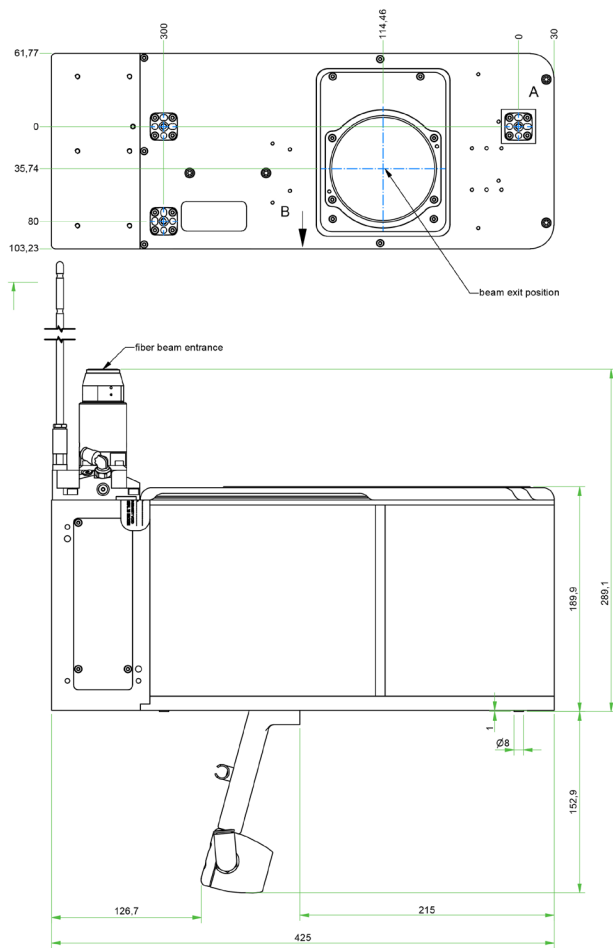

Notes:

All angles are in optical degrees, unless otherwise noted. Dimensions are in millimeters. All specifications are subject to change without notice.

ELEPHANT 3-AXIS SCAN HEAD

FIBER ELEPHANT 50 MM

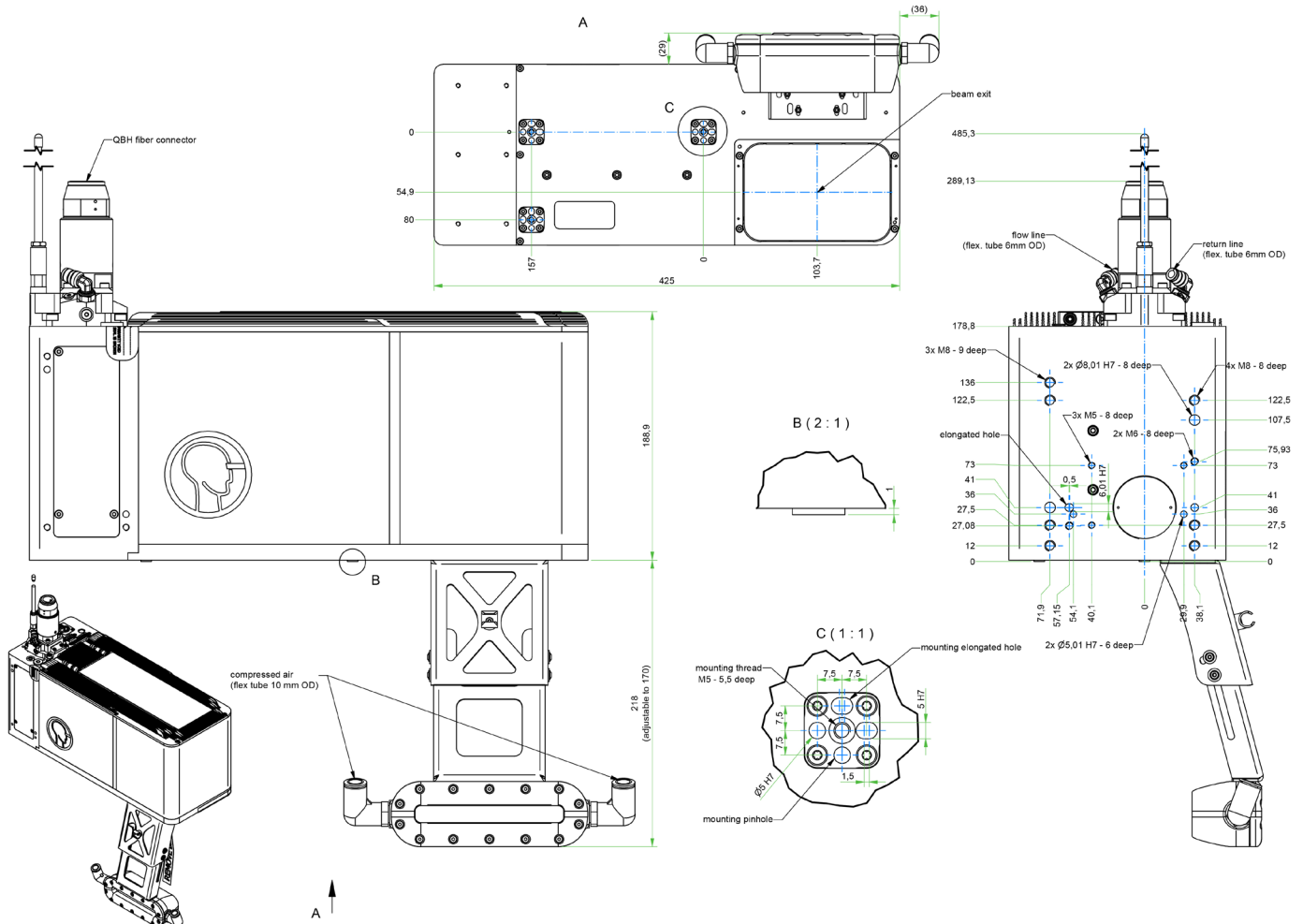

Notes:

All angles are in optical degrees, unless otherwise noted. Dimensions are in millimeters. All specifications are subject to change without notice.

CONTACT US

Americas, Asia Pacific

Novanta Headquarters
Bedford, USA
P +1-781-266-5700

Photonics@Novanta.com

Europe, Middle East, Africa

Novanta Europe GmbH
Wackersdorf, Germany
P +49 9431 7984-0

Milan, Italy
P +39-039-793-710

Photonics@Novanta.com

China

Novanta Sales & Service Office
Shenzhen, China
P +86-755-8280-5395

Suzhou, China
P +86-512-6283-7080

Photonics.China@Novanta.com

Japan

Novanta Service & Sales Office
Tokyo, Japan
P +81-3-5753-2460

Photonics.Japan@Novanta.com



www.NovantaPhotonics.com